

HEAT & ENERGY RECOVERY VENTILATOR

Energy Recovery Ventilation Specialist



HOLTOP

Beijing Holtop Air Conditioning Co., Ltd



COMPANY PROFILE

Holtop is the leading manufacturer in China specializing in the production of air to air heat recovery equipments. Founded in 2002, it is dedicated to the research and technology development in the field of heat recovery ventilation and energy saving air handling equipments for more than 15 years.

Holtop headquarters is located at the foot of Beijing Baiwangshan Mountain, covering area of 30,000 square meters. The manufacturing base is in Beijing's Badaling Economic Development Zone, covering an area of 60 acres, with an annual production capacity of 200,000 units of air heat recovery equipments. Holtop builds a sound certificate system of ISO9001, ISO14001 and OHSAS18001 as well as product certification systems. Moreover, it has a laboratory certified by national authority. As a well-known manufacturer in the field of heat recovery, Holtop has a strong R&D team and possesses dozens of national invention patents, and has participated in the compilation work of several national standards, and is also elected as Zhongguancun High-Tech Enterprise.

Holtop has mastered the core technology of heat recovery, independently developing products like plate and rotary heat exchangers, various heat & energy recovery systems and air handling units. Products have been exported to more than 41 countries and regions. Holtop continuously ranks the top in domestic market of heat and energy recovery ventilators.

Holtop will always committed to the mission of delivering highly efficient and energy saving products and solutions to improve indoor air quality, to ensure people's health and protect our earth.



CERTIFICATION

After years of dedication to the research and technology development in the filed of heat recovery and indoor air quality, Holtop has many achievements on the product innovative and quality management, which is certified by National and International authorities.



Product Patent Certificates



Energy Saving Product Certificates



Test lab Verification Certificates



CE Certificates



ISO9001 / ISO14001 / OHSAS18001 Certificates





CONTENTS

BRIEF INTRODUCTION TO COMPANY	02
HEAT&ENERGY RECOVERY VENTILATION SYSTEM	05
SELECTION GUIDE	06
TH SERIES, SUSPENDED TYPE	08
TZ SERIES, SUSPENDED TYPE	09
MEDIUM AIRFLOW SERIES	10
LARGE AIRFLOW SERIES	13
BRIEF INTRODUCTION TO HEAT EXCHANGER	15



BENEFITS

OF HEAT&ENERGY RECOVERY VENTILATION SYSTEM



Effective Ventilation

Introduces outdoor fresh air into indoors, meanwhile expels the indoor stale air to outdoor, which makes you feel the comfort of nature.



High efficient energy recovery

The built-in high efficient heat exchanger can recover the energy from outgoing indoor air to coming fresh air while ventilating. It can recover over 70% energy.



Perfect silence design

It is designed with the worldwide fashionable structure and manufactured by the accurate moldings. According to the principle of hydrokinetics, it achieves the perfect silent effect by using the micro-punch anechoic technology.



Air filtration and purification

The inner air filters are professionally designed to remove the pollutants of the incoming air, providing you the fresh and clean air.



By-pass function

By-pass function enables the unit to make natural ventilation in suitable climates, which can prolong the service life of the heat exchanger.



High airproof feature and easy maintenance

The heat exchanger is connected with the equipment by the in-mold rail, and embedded with the special soft and dense sealing materials. It can be drew out by hand and is easy to maintain. At the same time, it can ensure that the fresh air and exhaust air are completely separated, avoiding the cross pollution.

1. Choose the proper installation types based on the building structure
2. Determine the fresh airflow required according to the use, size and number of persons
3. Select the right specifications and quantity according to the determined fresh airflow

Airflow required in residential buildings

Rooms type	Non-smoking					Slight smoking		Heavy Smoking
	Ordinary ward	Gym	Theater & mall	Office	Computer room	Dining room	VIP room	Meeting room
Personal fresh air consumption(m ³ /h) (Q)	17-42	8-20	8.5-21	25-62	40-100	20-50	30-75	50-125
Air changes per hour (P)	1.06-2.65	0.50-1.25	1.06-2.66	1.56-3.90	2.50-6.25	1.25-3.13	1.88-4.69	3.13-7.81

Example

The area of a computer room is 60 sq. meters (S=60), the net height is 3 meters (H=3), and there are 10 persons (N=10) in it.

If it is calculated according to “Personal fresh air consumption”, and assume that: Q=70, the result is Q1 =N*Q=10*70=700(m³/h)

If it is calculated according to “Air changes per hour”, and assume that: P=5, the result is Q2 =P*S*H=5*60*3=900(m³)

Since Q2 > Q1 , Q2 is better for selecting the unit.

As to special industry such as hospitals (surgery and the special nursing rooms), labs, workshops, airflow required should be determined in conformity with regulations concerned.

Model description

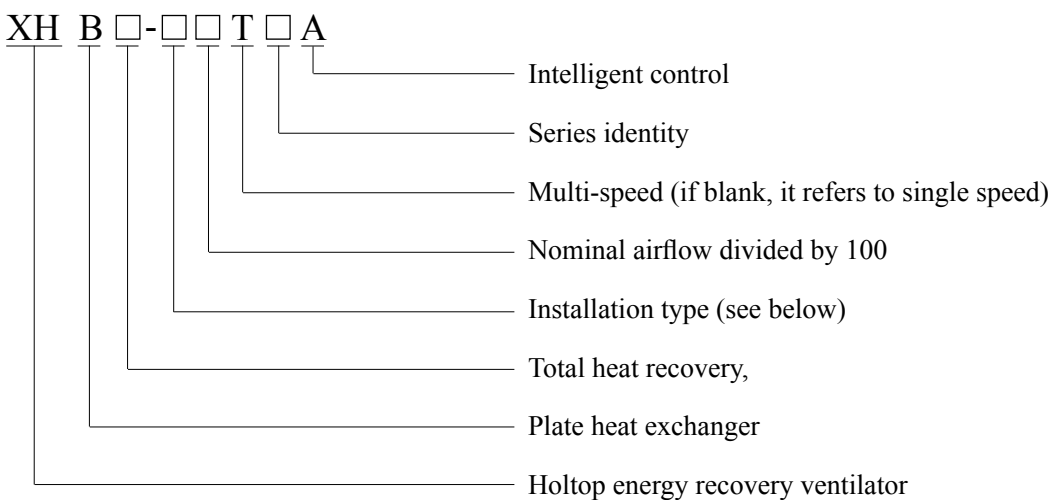

Installation type

D-Suspended type, L-Floor type

Example

XHBQ-D10TH refers to suspended type ERV with total heat exchanger, TH series, airflow of 1000m³/h, 3 speeds.

Product series	Installation type	Heat recovery type	Enthalpy	Airlow range										
				150	200	250	300	350	400	600	800	1000	1300	
TH series	Suspended	●												
TZ series		●												
				1500	2000	2500	3000	4000	5000	6000	7500	10000	15000	
TG series	Suspended / Floor standing	●												
G series	Suspended	●												
D series	Floor standing	●												

Controller

Controller	 LH-10705		 10307		 HDK-08S
Type	Intelligent control				Standard control
Suitable series	*TH, *TZ	*TG	*TH, *TZ	*TG	*TH *TZ
Temperature display	OA/RA/SA/FR temp.		OA/RA/SA/FR temp.		Room temp.
Speed selection	●		●		●
Weekly timer	●		●		●
Bypass	Auto	×	Auto	×	Manually
External ON/OFF	●		●		×
Comfortable heater control	●		●		×
Defrosting	●		●		×
CO2 control	●		●		×
Filter alarm	●		●		●
Fault alarm	●		●		×
Data memory	●		●		×
Night free cooling	●	×	●	×	×
BMS integration	●		●		×
Humidity control	●		×		×
Defrosting heater control	●		●		×
Working condition monitor	●		●		×

● : Applicable × : Not Applicable

Remarks

- The standard control panel for G series and XHBQ-L40D~L60D is HDK-09D, with functions of independent ON/OFF of supply and exhaust fan, indoor temperature measurement and temperature value revision.
- XHBQ-L75D~L200D is using the control box with functions of independent ON/OFF of supply and exhaust fan, safe protection and fault alarm.

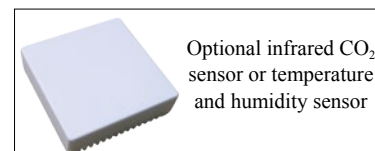



XHBQ-D2TH~D13TH

Features

- Airflow from 150-1300m³/h
- Energy recovery
- Crossflow heat exchanger
- Quiet operation
- Double filters
- Easy installation to ceiling
- By-pass function

Specifications

Model	Airflow(m ³ /h)			External pressure (Pa)			Enthalpy Efficiency (%)						Temp. Eff.(%)			Noise dB(A)			Volt. (V)	Current (A)	Input power (W)	N. W. (Kg)
							Summer			Winter												
	L	M	H	L	M	H	L	M	H	L	M	H	L	M	H	L	M	H				
XHBQ-D2TH	150	200	200	60	70	75	60	55	55	63	59	59	75	70	70	25	30	31.5	220	0.5	105	23
XHBQ-D3TH	250	300	300	75	82	85	62	57	57	65	61	61	73	68	68	27	34	34.5	220	0.56	117	25
XHBQ-D4TH	350	400	400	80	85	88	62	57	57	65	60	60	74	69	69	31	37	37.5	220	0.72	150	31
XHBQ-D6TH	500	600	600	89	92	97	63	59	59	67	61	61	76	70	70	29	35	39	220	0.96	200	36
XHBQ-D8TH	700	800	800	92	96	100	57	55	55	63	57	57	74	68	68	34	39	41	220	1.7	355	60
XHBQ-D10TH	900	1000	1000	80	85	86	60	58	58	64	62	62	76	70	70	34	38	42	220	2.1	440	70
XHBQ-D13TH	1000	1300	1300	75	85	90	58	56	56	62	59	59	76	70	70	38	41	43	220	3.4	710	79

Dimensions

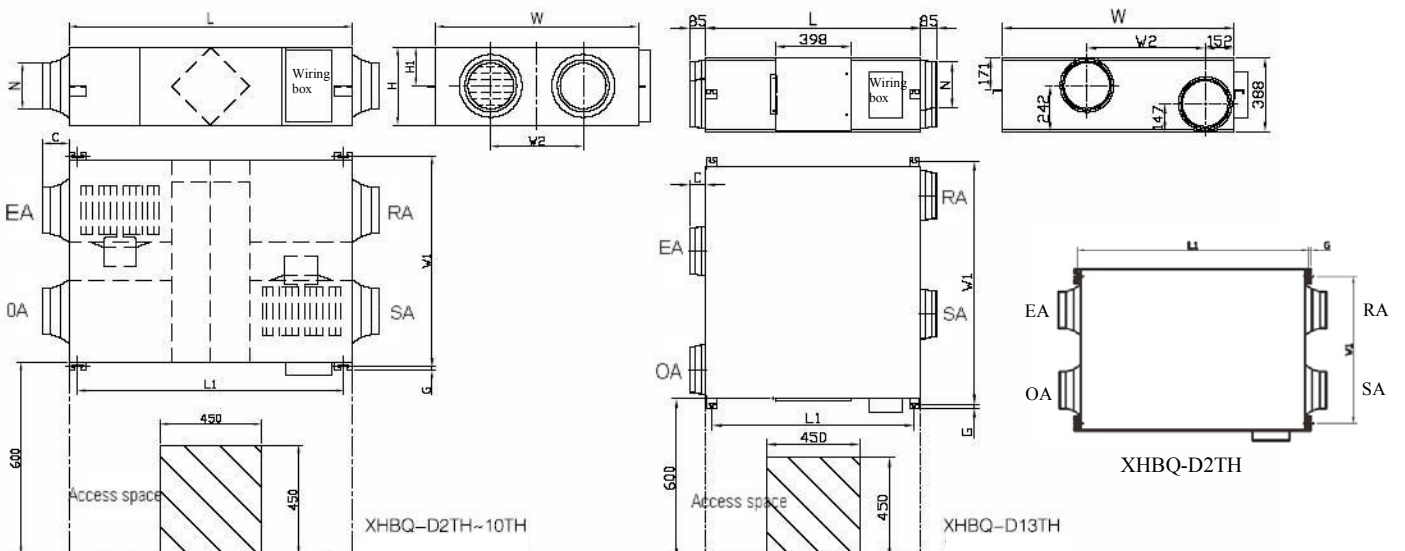

Model	L	L1	W	W1	W2	H	H1	C	G	N
XHBQ-D2TH	666	725	580	510	290	264	20	100	19	Φ144
XHBQ-D3TH	744	675	599	657	315	270	111	100	19	Φ144
XHBQ-D4TH	744	675	804	860	480	270	111	100	19	Φ144
XHBQ-D6TH	824	754	904	960	500	270	111	107	19	Φ194
XHBQ-D8TH	1116	1045	884	940	428	388	170	85	19	Φ242
XHBQ-D10TH	1116	1045	1134	1190	678	388	170	85	19	Φ242
XHBQ-D13TH	1129	1059	1216	1273	621	388	-	85	19	Φ242



XHBQ-D8TZ~D10TZ

Features

- Airflow from 800-1000m³/h
- Energy recovery
- High ESP construction
- Quiet operation
- Double filters
- Easy installation to ceiling
- By-pass function

Specifications

Model	Airflow(m ³ /h)			External pressure (Pa)			Enthalpy Efficiency (%)						Temp. Eff. (%)			Noise dB(A)			Volt. (V)	Current (A)	Input power (W)	N. W. (Kg)
							Summer			Winter												
	L	M	H	L	M	H	L	M	H	L	M	H	L	M	H	L	M	H				
XHBQ-D8TZ	680	800	800	120	125	170	58	55	55	64	57	57	75	68	68	37	40	43	220	2.8	585	60
XHBQ-D10TZ	840	1000	1000	105	120	175	60	57	57	63	61	61	75	69	69	36	42	44	220	3.3	690	79

Dimensions

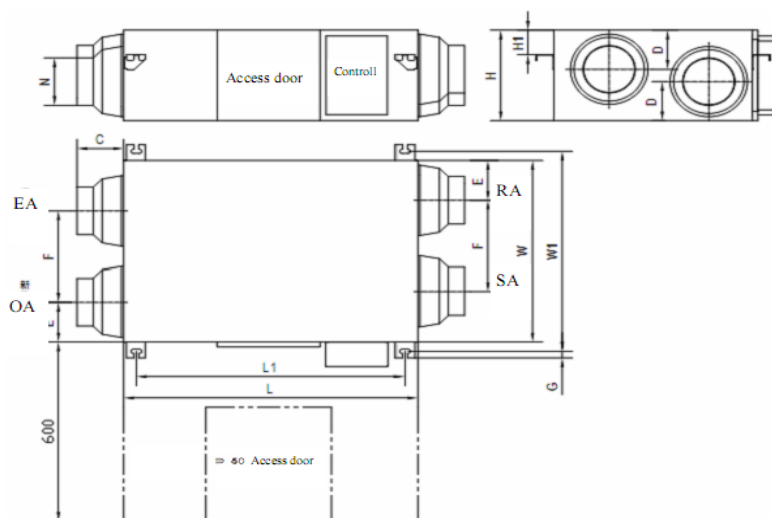

Model	L	L1	W	W1	H	H1	N	C	D	E	F	G
XHBQ-D8TZ	1126	1056	834	891	388	169	Φ242	86	157	152	436	21
XHBQ-D10TZ	1129	1060	1216	1273	388	171	Φ242	86	147	152	621	21



XHBQ-D15TG~D30TG

Features

- Energy recovery
- Double skin panel with PU insulation of 20mm
- Quiet operation
- Improved design with higher external static pressure
- Innovative access space design
- Double filters

Specifications

Model	Airflow m ³ /h			External pressure (Pa)			Enthalpy Efficiency (%)						Temp. Eff.(%)			Noise dB(A)			Volt. (V)	Current(A)			Input power (W)			N. W. (Kg)
	L	M	H	L	M	H	Summer			Winter			L	M	H	L	M	H		L	M	H	L	M	H	
							L	M	H	L	M	H														
XHBQ-D15TG	1000	1500	1500	84	135	163	69	66	66	74	70	70	74	71	71	46	49	51	220	2.3	3.6	3.8	485	740	785	110
XHBQ-D20TG	1200	2000	2000	110	132	176	65	62	62	73	71	71	74	71	71	49	51	53		3.0	4.6	4.8 7.4	650	980	1020	112
XHBQ-D25TG	2000	2500	2500	140	170	200	64	61	61	72	70	70	73	70	70	50	52	55		4.5	6.0	6.3	940	1250	1300	130
XHBQ-D30TG	2500	3000	3000	150	180	210	63	60	60	71	69	69	73	70	70	51	54	57		6.5	8.7	9.0	1400	1870	1950	142

Dimensions

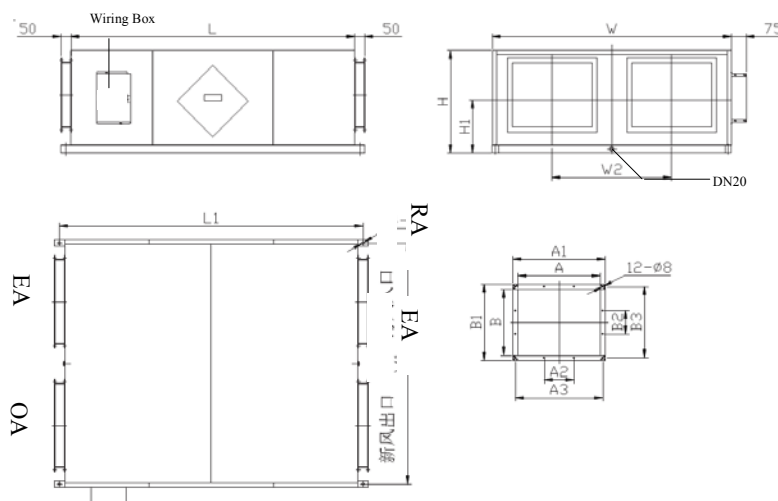

XHBQ-D115TG~D30TG

Model	L	L1	W	W1	W2	H	H1	A	A1	A2	A3	B	B1	B2	B3
XHBQ-D15TG	1426	1476	1200	1170	600	510	290	400	450	145	425	320	370	115	345
XHBQ-D20TG	1426	1476	1200	1170	600	510	290	400	450	145	425	320	370	115	345
XHBQ-D25TG	1700	1750	1400	1370	700	590	345	500	550	175	525	350	400	125	375
XHBQ-D30TG	1800	1850	1500	1470	700	660	415	500	550	175	525	350	400	125	375



XHBQ-D40G~D60G

Features

- Energy recovery
- Double skin panel with PU insulation of 20mm
- Quiet operation
- Improved design with higher external static pressure
- Innovative access space design
- Double filters

Specifications

Model	Airflow (m ³ /h)	External pressure (Pa)	Enthalpy Efficiency (%)		Temp. Eff.(%)	Noise dB(A)	Volt. (V)	Current (A)	Input power (W)	N. W. (Kg)
			Summer	Winter						
XHBQ-D40G	4000	260	62	69	70	59	380	7.5	3000	240
XHBQ-D50G	5000	260	61	64	70	68		8.3	3000	300
XHBQ-D60G	6000	300	60	62	68	70		12.7	4400	305

Dimensions

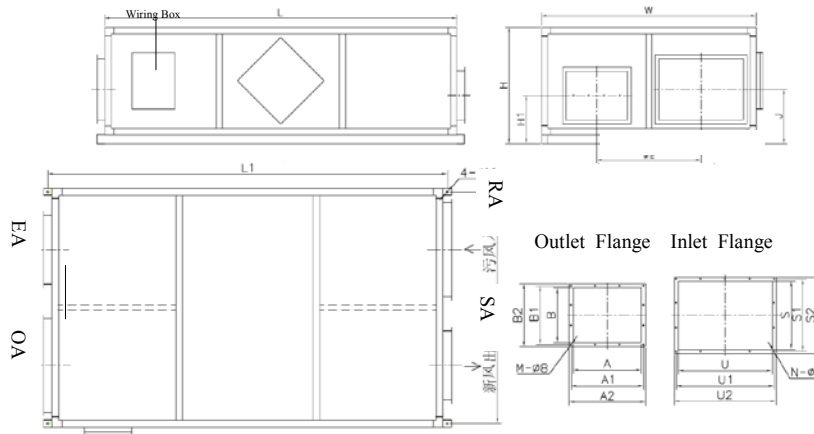

XHBQ-D40G~D60G

Model	L	L1	W	W1	W2	H	H1	J	A	A1	A2	B	B1	B2	S	S1	S2	U	U1	U2
XHBQ-D40G	2200	2250	1400	1360	680	760	310	350	400	425	450	320	345	370	400	425	450	550	575	600
XHBQ-D50G	2400	2450	1700	1660	830	900	320	395	500	525	550	350	375	400	500	525	550	600	625	650
XHBQ-D60G	2400	2450	1700	1660	830	900	320	395	500	525	550	350	375	400	500	525	550	600	625	650

Installation

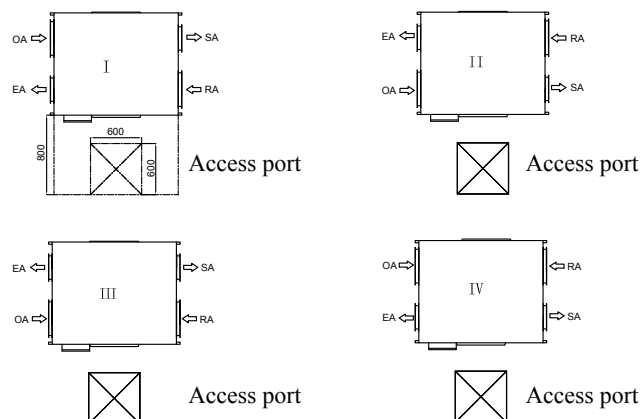



XHBQ-L15TG~L30TG, XHBQ-L40D~L60D

Features

- Airflow from 1000-3000m³/h
- Energy recovery
- Both suspended installation and floor installation available
- Quiet operation
- Double filters

Specifications

Model	Airflow (m ³ /h)			External pressure (Pa)			Enthalpy Efficiency(%)						Temp. Eff. (%)			Noise dB(A)			Volt. (V)	Current(A)			Input power (W)			N. W. (Kg)
	L	M	H	L	M	H	Summer			Winter			L	M	H	L	M	H		L	M	H	L	M	H	
							L	M	H	L	M	H														
XHBQ-L15TG	1000	1500	1500	84	135	163	69	66	66	74	70	70	74	71	71	46	49	51	220	2.2	3.2	3.6	450	700	770	140
XHBQ-L20TG	1200	2000	2000	110	132	176	65	62	62	73	71	71	74	71	71	49	51	53		2.8	4.1	4.4	600	930	980	148
XHBQ-L25TG	2000	2500	2500	140	170	200	64	61	61	72	70	70	73	70	70	50	52	55		4.2	5.8	6.1	940	1250	1300	190
XHBQ-L30TG	2500	3000	3000	150	180	210	63	60	60	71	69	69	73	70	70	51	54	57		5.2	7.4	7.7	1150	1600	1680	203

Model	Airflow (m ³ /h)	External pressure (Pa)	Enthalpy Efficiency (%)		Temp. Eff. (%)	Noise	Volt. (V)	Current (A)	Fan power (W)	N. W. (Kg)
			Summer	Winter						
XHBQ-L40D	4000	260	62	69	70	59	380	7.6	3000	266
XHBQ-L50D	5000	260	61	64	70	68	380	11	4400	342
XHBQ-L60D	6000	300	60	62	68	70	380	14	6000	342

Dimensions

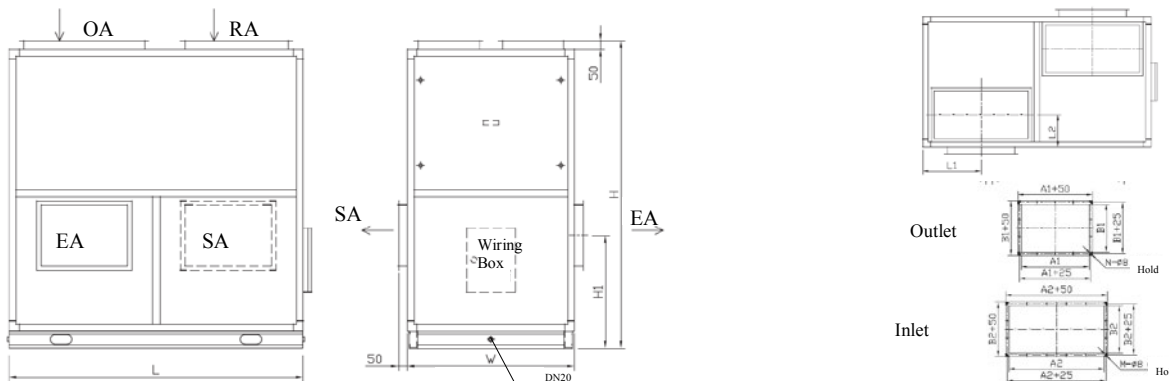

Model	L	L1	L2	W	H	H1	A1	B1	A2	B2	M	N
XHBQ-L15TG	1250	322.5	190	616	1220	450	400	320	450	250	10	10
XHBQ-L20TG	1250	322.5	190	616	1220	450	400	320	450	250	10	10
XHBQ-L25TG	1450	372.5	190	690	1295	450	500	350	550	250	10	10
XHBQ-L30TG	1450	372.5	190	754	1359	465	500	350	550	250	10	10
XHBQ-L40D	1400	360	203	825	1540	575	400	320	590	275	12	12
XHBQ-L50D	1700	435	240	967	1770	648	500	350	700	350	16	14
XHBQ-L60D	1700	435	240	967	1770	648	500	350	700	350	16	14



XHBQ-L75D~L150D

Features

- Airflow from 7500-30000m³/h
- Installed on the floor or in machine room
- Double filters
- Flexible and remote setting of control box

Application

Suitable for lab, classroom, computer room, conference room, open office, commercial building, hotel lobby, dining places etc.

Specifications

Model	Airflow (m ³ /h)	External pressure(Pa)	Enthalpy Efficiency(%)		Temp. Eff. (%)	Noise dB(A)	Volt. (V)	Current (A)	Fan power(W)	N. W. (Kg)
			Summer	Winter						
XHBQ-L75D	7500	290	64	69	72	76	380	14	6000	472
XHBQ-L100D	10000	340	63	69	72	80	380	24	11000	757
XHBQ-L150D	15000	450	64	67	72	85	380	30.4	15000	1075

Dimensions

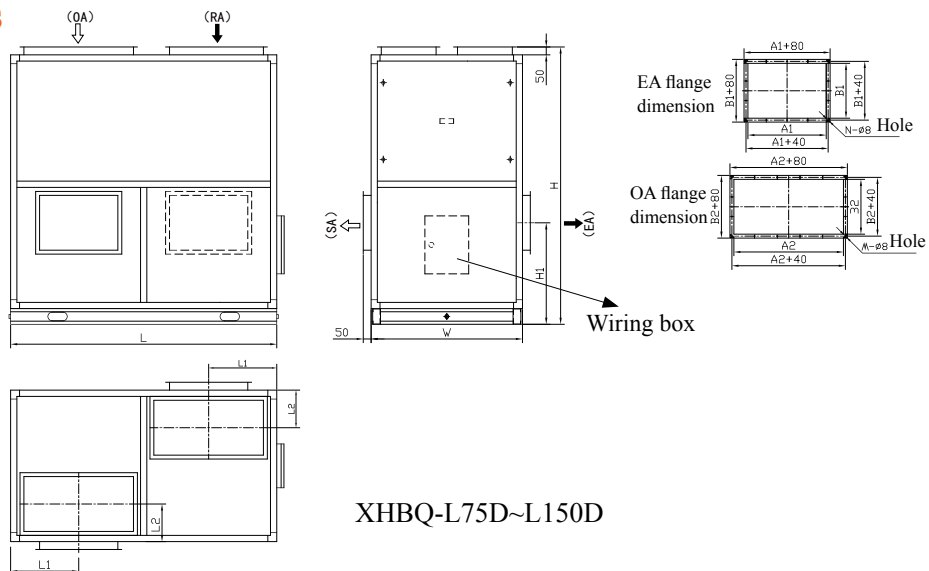

XHBQ-L75D~L150D

Model	L	L1	L2	W	H	H1	A1	B1	A2	B2	M	N
XHBQ-L75D	1710	438	280	1251	2100	657	500	400	700	400	12	10
XHBQ-L100D	2125	541	305	1251	2220	703	630	500	800	450	14	12
XHBQ-L150D	2056	524	330	1392	2498	818	630	500	800	500	16	12

The plate heat exchanger is one of the air-to-air heat exchangers. The outdoor air and exhaust air are separated by the plates to ensure the air tightness while transferring the heat. It has no movement parts, so it's more reliable and has longer service life.

According to the airflow directions of the heat exchanger, it is categorized into crossflow type, counterflow type, and cross-counter flow type.



Total heat exchanger is made of ER paper which is featured by high moisture permeability, good air tightness, excellent tear resistance, and aging resistance. The clearance between the fibers is very small, so only the moisture molecules of small diameter can go through, the odor molecules of larger diameter are unable to pass through it. By this means, the temperature and humidity can be recovered smoothly, and prevent the pollutants infiltrating to the fresh air.

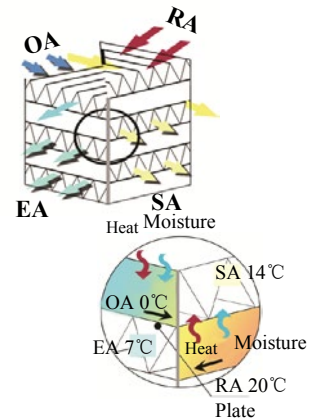

High-efficient counterflow plate total heat exchanger is also an energy recovery for direct air-to-air total heat exchange. Since the two airstreams flow counter and increase the heat exchanging area, it is more efficient than the crossflow heat exchanger and applied to the Holtop ventilators of high efficient series (TP series).

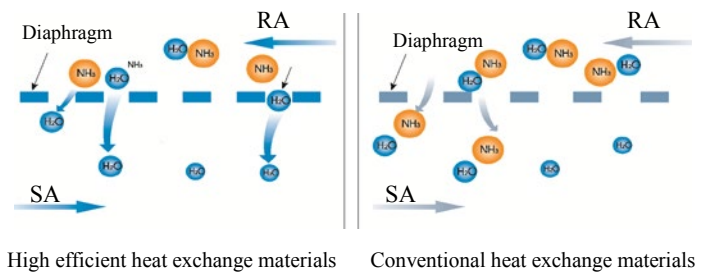
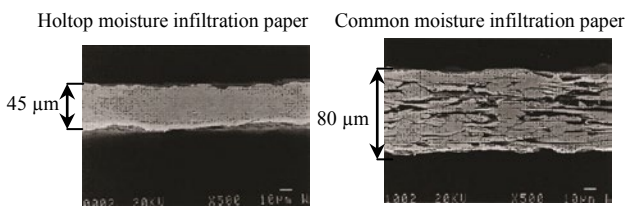
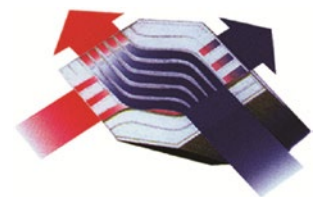

Gas molecules type	Carbon dioxide (CO ₂)	Ammonia (NH ₃)	Methane (CH ₄)	Vapor(H ₂ O)	The clearance of fiber
Diameters (nm)	0.324	0.308	0.324	0.288	0.3 (for reference)

HOLTOP

Beijing Holtop Air Conditioning Co., Ltd.

Factory address : No. 5 Yard, 7th Guanggu Street, Badaling Economic Development Zone, Yanqing District, Beijing, China

International marketing center

No.12 Zhengyi Ave, Hebei District, Tianjin, China

Tel: 86-22-26420391

Website: www.holtop.net

E-mail: export@holtop.com.cn



Data is subject to changes without notification due to product improvement