

HOLTOP



Filtration Ventilation System

Bring Forest Fresh Air to Your Life !





Indoor air quality
is seriously affected
by outdoor air
pollution

Indoor air pollution hazards

Catching colds

Fetal deformity

Allergies

Dizzy, nausea

Immunity decline

Bad smell

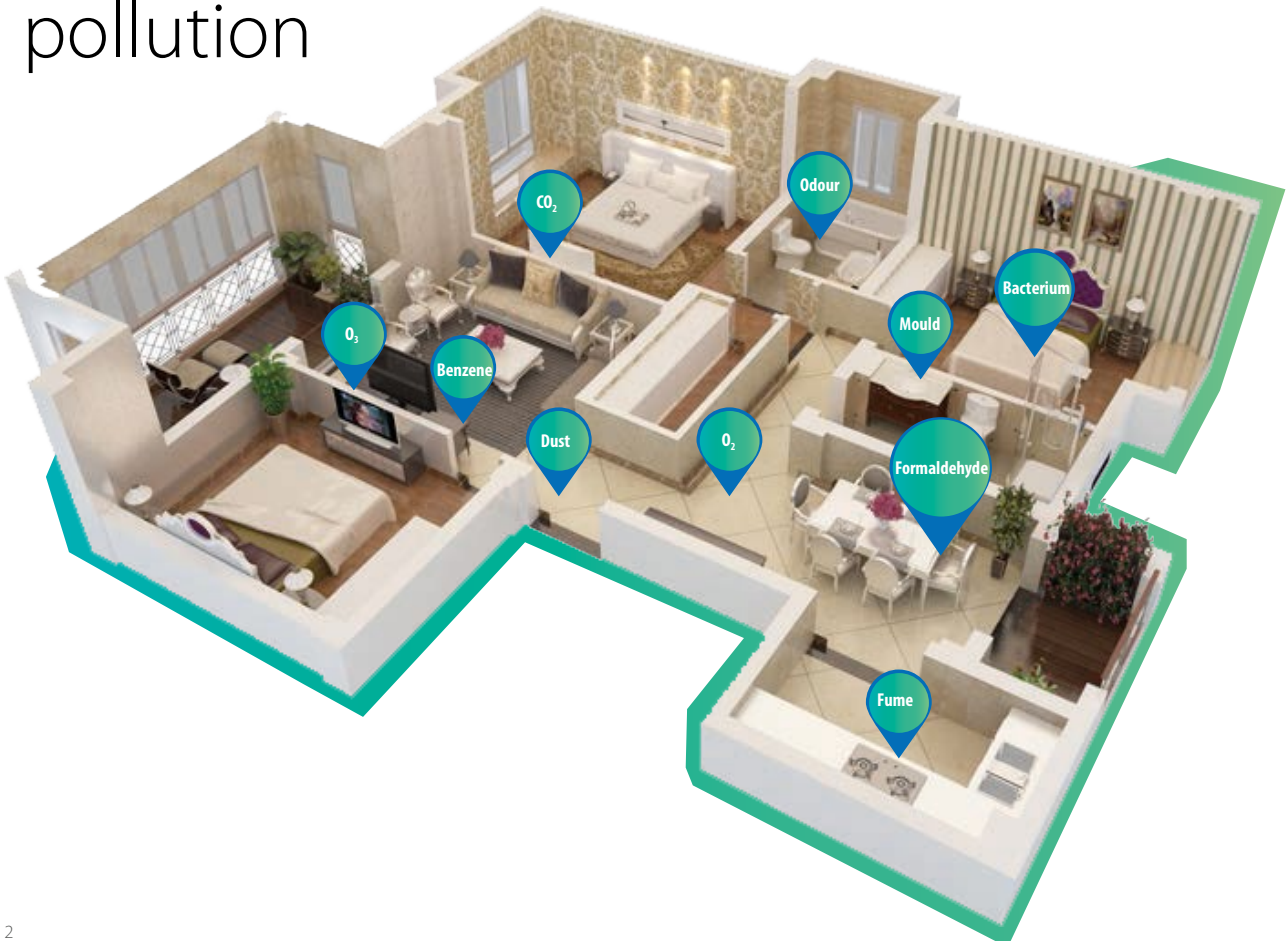

Excellent **Indoor Air Quality**, High Oxygen Content



Multi-stage gradual filters to remove dust, PM2.5, bacteria and harmful substances



Providing fresh air all the time to make you feel breathing in the nature.



Smart controller available to work with ERV or independently to monitor indoor air quality



Easy installation and maintenance, 20% less thickness

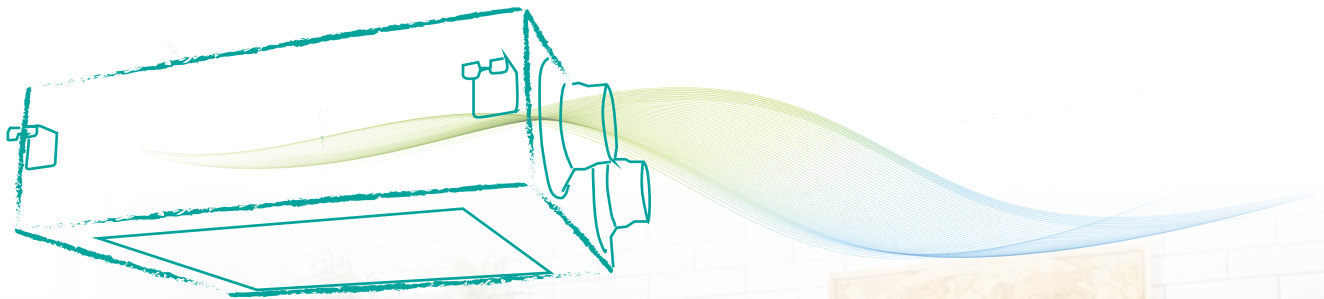



Sub HEPA F9 filter

- Double high efficient filters;
- Operating theatre clean class material;
- Filtration class is up to F9, passing national GB/T 14295 standards.



Filtration effectiveness **95%**



The single-way fresh air filtration system supplies outdoor fresh air to room with high purification. It's equipped with double filters with PM2.5 filtration rate over 95%. It can be used to work together with Holtop energy recovery ventilator for better air purification either used independently for air purification in air conditioning system.

It has the optional functions of indoor circulation. In the situation when it's not suitable to introduce outdoor fresh air, it can bypass the air in the room for indoor air purification only.

One product can solve all your air quality problem: fresh air, air purification and cleanness with much lower costs.

Installations

Single-way Fresh Air Filtration System Installation



Single-way Fresh Air Filtration + Energy Recovery Ventilation System Installation

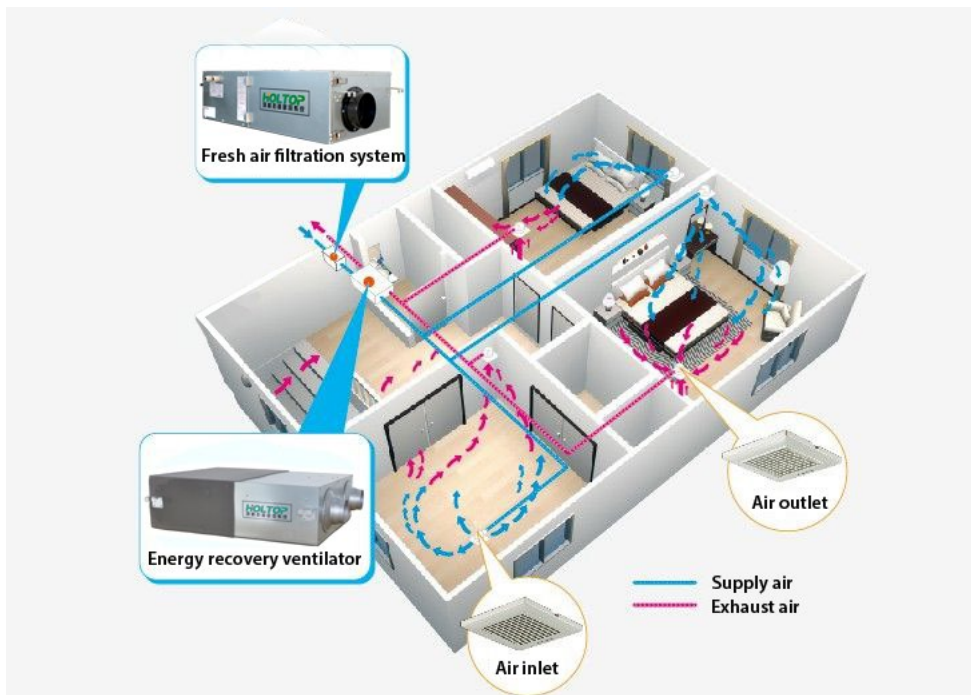

Fresh Air Filtration System



FEATURES

- Double filters, PM2.5 filtration over 95%
- Zinc free galvanized steel plate, high Corrosion resistance and long service life
- Built-in low-noise blower
- 3 speed high efficiency motor, running smoothly with low noise
- Super thin design and fit for installation

SPECIFICATIONS

Model	Airflow (m3/h)			External pressure (Pa)			Input power (W)			Current (A)			Noise dB(A)			Power supply	Weight (kg)
	L	M	H	L	M	H	L	M	H	L	M	H	L	M	H		
DX1.5B2	120	150	150	55	68	88	45	53	56	0.25	0.3	0.31	25	31	32	220V/50Hz	14
DX2.5B2	210	250	250	45	55	65	59	82	90	0.3	0.41	0.45	30	33	34	220V/50Hz	14.3
DX3.5B2	260	350	350	53	70	80	113	172	180	0.58	0.83	0.85	32	36	37	220V/50Hz	18.5
KJ-06C	350	550	600	25	20	25	90	103	115	0.45	0.52	0.56	32	37	39	220V/50Hz	25
KJ-08C	700	800	800	130	150	170	140	200	238	0.7	1	1.2	35	39	41	220V/50Hz	25
KJ-10C	900	1000	1000	80	90	120	190	235	280	1	1.2	1.4	35	40	43	220V/50Hz	25
KJ-13C	1000	1300	1300	40	60	90	320	398	500	1.7	2.1	2.5	39	43	45	220V/50Hz	25

DIMENSIONS

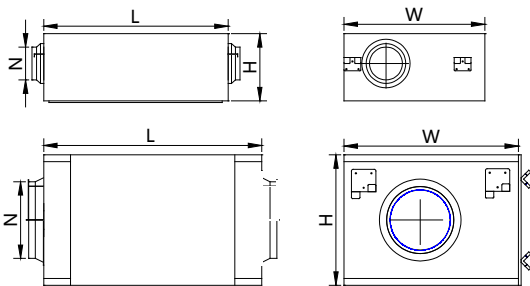

Model	L	W	H	N
DX1.5B2	550	420	200	Φ98
DX12.5B2	550	420	200	Φ144
DX3.5B2	600	500	220	Φ144
KJ-06C	602	460	270	Φ194
KJ-08C	650	520	388	Φ242
KJ-10C	650	520	388	Φ242
KJ-13C	650	520	388	Φ242

Fresh Air Filtration System



FEATURES

- Double or triple filters, progressive filtration class to increase effectiveness.
- Double filters: plate type coarse filter and bag type medium filter, the ultimate efficiency rating at F5.
- Triple filters: based on the two grades of filtration class, adding HEPA filter, the ultimate efficiency rating at H10.
- Built-in low-noise blower
- Can work separately or connected to HRV and air conditioner
- Easy to install and maintain

SPECIFICATIONS

Filtration type	Model	Airflow	External pressure	Dimensions			Spigot size	Voltage	Rated power	Weight
		m3/h	Pa	L	W	H	mm	V	W	Kg
G3+F5 Filters	KJ-06	600	120	1182	599	327	Φ194	220	60	23
	KJ-10	1000	120	1485	653	780	Φ242	220	180	26
	KJD-15TG	1500	200	1485	653	780	400×320	220	320	55
	KJD-20TG	2000	220	1485	653	780	400×320	220	375	57
	KJD-25TG	2500	240	1485	973	780	500×350	220	450	59
	KJD-30TG	3000	250	1485	973	780	500×350	220	550	79
	KJD-40B	4000	300	1530	1278	790	500×400	380	1500	98
	KJD-50B	5000	300	1530	1278	900	600×500	380	1500	103
	KJL-15TG	1500	200	1485	653	780	450×250	220	320	55
	KJL-20TG	2000	220	1485	653	780	450×250	220	375	57
	KJL-25TG	2500	240	1485	973	780	550×250	220	450	59
	KJL-30TG	3000	250	1485	973	780	550×250	220	550	79
	KJD-40A	4000	300	1530	1278	790	590×275	380	1500	98
	KJD-50A	5000	300	1530	1278	900	700×350	380	1500	103
	KJD-75A	7500	400	1530	1278	900	700×400	380	3000	135
	KJD-100A	10000	500	2050	1278	1440	800×450	380	5500	230
	KJD-150A	15000	620	2050	1888	1440	800×500	380	7500	280
G3+F5+H10 Filters	KJG-06A	600	90	1680	599	327	194	220	60	27
	KJG-10A	1000	85	1770	599	388	242	220	180	31
	KJGD-15TG	1500	200	2290	668	780	400×320	220	320	62
	KJGD-20TG	2000	220	2290	668	780	400×320	220	375	64
	KJGD-25TG	2500	240	2290	973	780	500×350	220	450	88
	KJGD-30TG	3000	250	2290	973	780	500×350	220	550	88
	KJGD-40A	4000	300	2500	1278	790	550×400	380	1500	109
	KJGD-50A	5000	300	2500	1278	900	600×500	380	2200	126
	KJGL-15TG	1500	200	2290	668	780	450×250	220	320	62
	KJGL-20TG	2000	220	2290	668	780	450×250	220	375	64
	KJGL-25TG	2500	240	2290	973	780	550×250	220	450	88
	KJGL-30TG	3000	250	2290	973	780	550×250	220	550	88
	KJGL-50A	5000	300	2500	1278	900	700×350	380	2200	126
	KJGL-75A	7500	400	2500	1278	900	700×400	380	3000	148
	KJGL-100A	10000	500	3100	1278	1440	800×450	380	5500	252

Note: KJ/KJD/KJGD series is suspended type, and KJL/KJGL series is floor type.

Fresh Air Filtration System with Internal Circulation System

FEATURES

- PM2.5 High efficiency filter
- By-pass functions for indoor air purification
- Built-in low-noise blower
- 4P Asynchronous motor
- Easy to maintain
- Ultra thin design and fit for installation



INSTALLATIONS

Ventilation for apartments

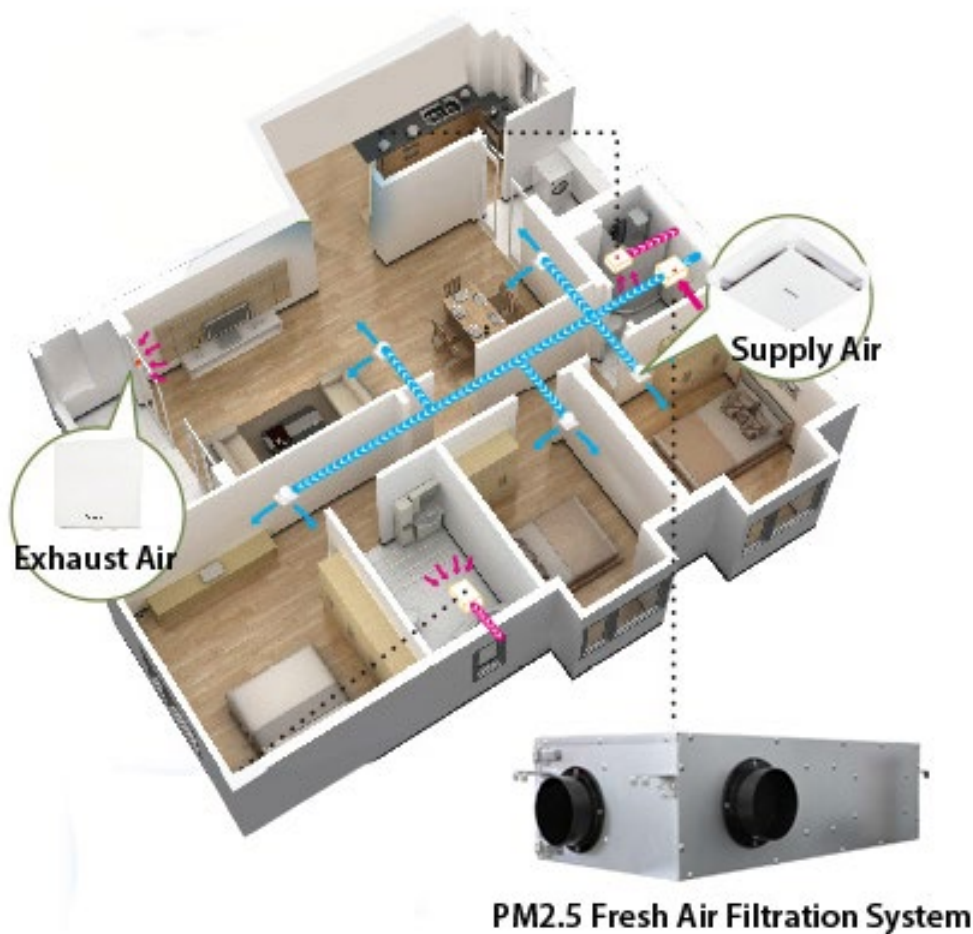

VENTILATION FOR ATTIC

All in one design

No need to install centrifugal fan, filtration box and motorized diverting branch with ducts separately, saving labor costs and installation materials and less construction garbages.

Recycles Lost Heat

Warm air rising into the roof from home heating is recovered and recycled back into the house, resulting in much reduced heating costs.

Anti Condensation

The ventilator forces out the stale moist air that causes problem condensation and damp conditions, replacing it with clean dry air

Solar Heat Saving

Roof and ceiling spaces are excellent passive collector of solar energy. This warm dry air is supplied back into the house as the ventilator forces the warmed air into the cooler living spaces.

Air purified

The outdoor air will be purified before supplied to room for healthy life. Integrated with F9 filter to stop outside air pollutions like PM2.5 into house. Higher air cleanness and cleaner house, save time and money to clean the house.

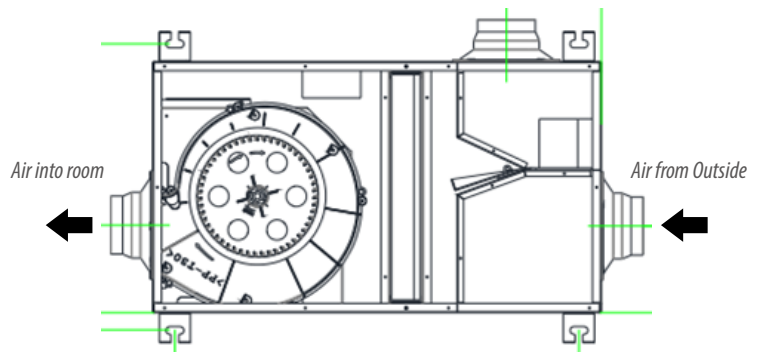
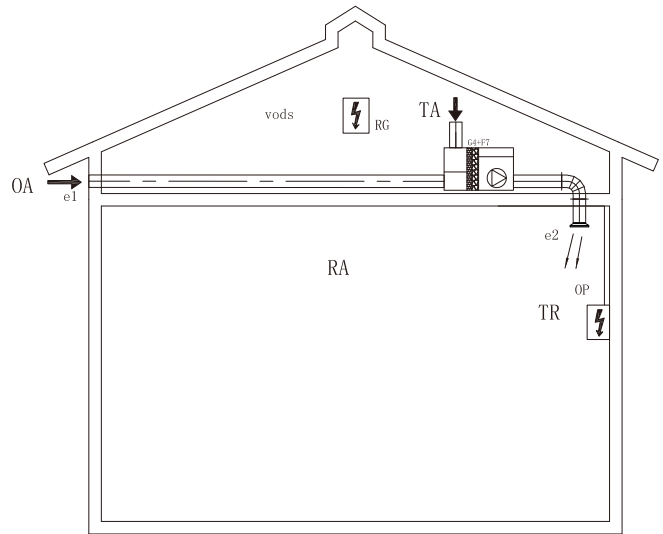

INTELLIGENT CONTROL FUNCTIONS

Heating/Cooling/Auto mode

Under heating mode, ventilator will bring fresh air from OA or TA whoever with higher temperature.

Under cooling mode, ventilator will bring fresh air from OA or TA whoever with lower temperature.

Under auto mode, ventilator will compare indoor temperature (RA) and setting temperature (TR), if $TR > RA$, runs heating mode, if $TR < RA$, runs cooling mode.

Fan speed can run manually or automatically under each mode.





FEATURES

- PM2.5 High efficiency filter
- By-pass functions for indoor air purification
- Built-in low-noise blower
- 4P Asynchronous motor
- Easy to maintain
- Ultra thin design and fit for installation

SPECIFICATIONS



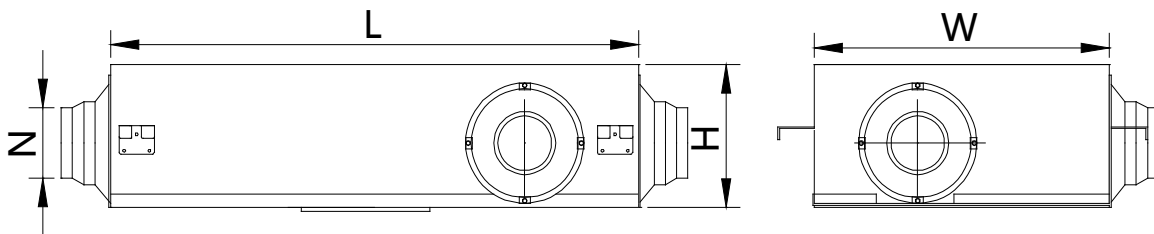

Model	Airflow			External pressure			Input power			Current			Noise			Power supply	Weight
	(m3/h)			(Pa)			(W)			(A)			dB(A)				
	L	M	H	L	M	H	L	M	H	L	M	H	L	M	H		
DX1.5B3	120	150	150	55	68	88	45	47	48	0.22	0.22	0.23	25	31	32	220V/50Hz	8.5
DX2.5B3	210	250	250	45	55	65	60	72	75	0.29	0.34	0.6	30	33	34	220V/50Hz	19
DX3.5B3	260	350	350	53	70	80	106	131	139	0.51	0.63	0.67	32	36	37	220V/50Hz	24

DIMENSIONS



Model	L	W	H	N
DX1.5B3	752	420	200	Φ98
DX2.5B3	752	420	200	Φ144
DX3.5B3	802	500	220	Φ144

CONTROL SYSTEM

Controller	LH-10705	10307	HDK-08S-A	HDK-3
				
Suitable series	*DX1.5B2~3.5B2, *KJ-06C~13C, *KJ-06~30TG, KJL-15TG~30TG, *KJ-06A~30TG, *KJGL-15TG~30TG	*DX1.5B2~3.5B2, *KJ-06C~13C, *KJ-06~30TG, KJL-15TG~30TG, *KJ-06A~30TG, *KJGL-15TG~30TG	*DX1.5B2~3.5B2, *KJ-06C~13C, *KJ-06~30TG, KJL-15TG~30TG, *KJ-06A~30TG, *KJGL-15TG~30TG	*DX1.5B3~3.5B3 *DX1.5B2~3.5B2, *KJ-06C~13C, *KJ-06~30TG, KJL-15TG~30TG, *KJ-06A~30TG, *KJGL-15TG~30TG
Temperature display	OA/SA temp.	OA/SA temp.	Room temp.	-
Speed selection	√	√	√	√
Weekly timer	√	√	√	-
Bypass	-	-	-	Manually
External ON/OFF	√	√	-	-
Comfortable heater control	√	√	-	-
CO2 control	√	√	-	-
Filter alarm	√	√	√	-
Fault alarm	√	√	-	-
Data memory	√	√	-	-
BMS integration	√	√	-	-
Humidity control	√	√	-	-
Defrosting heater control	√	√	-	-
Working condition monitor	√	√	-	-

Remarks

1. KJD-40B~50B, KJD-40A~KJD-150A, KJGD-40A~50A, KJGL-50A~KJGL-100A is using the control box with functions of ON/OFF, safe protection and fault alarm.



Optional infrared CO₂ sensor / Temperature and Humidity Sensor